



Characterization of BaCl₂ scintillation crystal at low temperature

M.J. Kim^a, H.J. Kim^{a,*}, H. Park^a, Sunghwan Kim^b, Jung-in Kim^c

^a Department of Physics, Kyungpook National University, Daegu 702-701, Republic of Korea

^b Department of Radiation Science, Cheongju University, Cheongju 360-764, Republic of Korea

^c Interdisciplinary Program in Radiation Applied Life Science, College of Medicine, Seoul National University, Seoul 110-744, Republic of Korea

ARTICLE INFO

Article history:

Received 7 June 2010

Received in revised form

23 December 2010

Accepted 29 December 2010

Available online 5 January 2011

Keywords:

High energy experiment

Calorimeter

Crystal scintillator

BaCl₂

Fast decay time

ABSTRACT

A BaCl₂ scintillation crystal was grown by the Czochralski method. The grown crystal was cut to a size of 10 × 10 × 5 mm³. The scintillation properties of the crystal such as pulse height spectra, energy resolution, and fluorescence decay time were measured with a ¹³⁷Cs (662 keV) γ-ray source at room temperature. We measured the temperature dependence of the scintillation light yield and decay time with a bi-alkali photomultiplier tube for the BaCl₂ crystal. The BaCl₂ crystal was cooled down with compressed helium gas from room temperature to 10 K. We measured the light yield and decay time changes of the BaCl₂ crystal from 10 K to room temperature. The light yield of the BaCl₂ at 200 K was four times higher than that at room temperature. The decay time increases as temperature decreases. The BaCl₂ scintillation crystal has a low light yield but a fast decay time so that it can be a calorimeter candidate for high energy physics experiments.

© 2011 Elsevier B.V. All rights reserved.

1. Introduction

Recently, various new and improved inorganic scintillators have been investigated with the goal of finding heavy, fast, and more efficient materials with a high light yield and good energy resolution for X- and γ-ray radiation detectors. These scintillators are useful not only in nuclear physics, high energy physics, astrophysics, but also medical imaging and industrial applications such as security systems at airports [1–3].

Halides of various metals are well-suited materials for scintillators. The most widely used materials in scintillation technology are alkali halide crystals. Crystals of alkaline-earth fluorides (CaF₂, SrF₂, and BaF₂) have high chemical, thermal, and radiation stability when compared to alkali halide crystals. The cross-sections for the interaction of Ca, Sr, Ba, and F atoms with thermal neutrons are substantially smaller than those of Na, Cs, and I atoms with thermal neutrons. Therefore, these fluorides have a much lower sensitivity to thermal neutrons than the alkali halide crystals. Consequently, alkaline-earth fluorides are suitable for monitoring neutrons against the γ background. Among the halides of elements in the second group, the crystals CdF₂, CdI₂, SrCl₂:Eu, and BaCl₂ are considered as candidate compounds for scintillators. The melting point of the BaCl₂ crystal is lower than that of alkaline-earth fluorides crystal. The atomic number of BaCl₂ is larger than that of SrCl₂. These properties provide an advantage in X- and γ-ray detection. The BaCl₂

scintillation crystal has low light yield but fast decay time. That is why it is useful for high energy physics experiments like pure CsI or PbWO₄ crystal [1–9].

We measured the scintillation properties of the BaCl₂ crystal with a ¹³⁷Cs (662 keV) γ-ray source and X-ray luminescence using an X-ray tube. In this paper, we present measurement results of pulse height spectra, energy resolution, relative light yield, fluorescence decay time, and X-ray luminescence at room temperature. We also measure the light yield and decay time changes of the BaCl₂ crystal from 10 K to room temperature for understanding the quenching mechanism of the BaCl₂ crystal.

2. Experiments

2.1. BaCl₂ crystal growing

The BaCl₂ single crystal was grown by the Czochralski technique in an induction heated platinum crucible with a diameter of 30 mm. The growing process was performed in an Ar-gas atmosphere with a pulling rate of 2–2.5 mm/h and rotation rate of 20–25 rpm. To reduce crystal cracks, a low thermal gradient was set up in the furnace. The chemical used for the crystal growth was BaCl₂ (99.95% purity, Sigma-Aldrich). The samples of BaCl₂ crystals with a dimension of 10 × 10 × 5 mm³ were cut from the grown crystals and polished using mixed Al₂O₃ powder (grain size of 0.02 μm) in mineral oil with a polishing cloth (Buehler, no. 40-7218) for scintillation characterization [10].

* Corresponding author.

E-mail address: hongjoo@knu.ac.kr (H.J. Kim).

2.2. Experimental setup

First, we studied the scintillation properties of the BaCl₂ at room temperature. The BaCl₂ crystal was wrapped in a few layers of the Teflon tape and optically coupled with a 2 in. bi-alkali photomultiplier tube (PMT), XP2260 made by Photonis, by optical grease. A signal from the PMT was fed to a preamplifier and then 400 MHz flash analog-to-digital converter (FADC) board made by NOTICE KOREA [11]. The digitized signal was read out by a Linux-based computer and the data were analyzed with the C++ based data analysis program, ROOT package [12].

We also measured the X-ray excited luminescence of the BaCl₂ crystal using an X-ray tube (DRGEM Co.). The BaCl₂ crystal was wrapped with several layers of Teflon tape except the one for attachment with an optical fiber. To avoid the light loss when the BaCl₂ crystal was attached to the optical fiber, a holder with a hole at its center was made from the Teflon material. Scintillation light from the crystal by the X-rays irradiation was transmitted to the QE65000 spectrometer produced by Ocean Optics Co. through the optical fiber. The QE65000 was cooled down to -15°C. The Windows cased software provided by the manufacturer of the spectrometer was used for plotting the X-rays induced emission spectrum of the crystal.

The temperature dependence on the light yield and decay time of the BaCl₂ crystal were measured with temperature changes from room temperature to 10 K. The BaCl₂ crystal was cooled down in a refrigerator to 10 K, with compressed helium gas. A quartz bar of ϕ 15 mm × 70 mm was used as light guide and the BaCl₂ crystal sample were placed in a vacuum environment of 10⁻²–10⁻³ Torr. The temperature of the refrigerator was

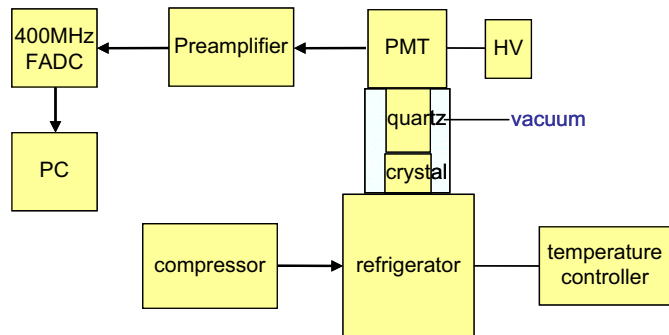

Fig. 1. Schematic diagram of the experimental setup for measuring the scintillation characteristics at low temperature.

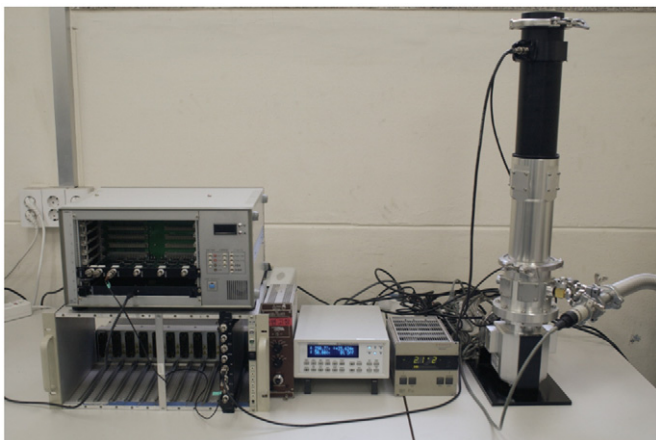

Fig. 2. Low temperature experimental setup with temperature controller and DAQ system.

controlled with a temperature controller, LakeShore 331. We used the ¹³⁷Cs (662 keV) γ-ray radioactive source to measure the pulse height spectra, energy resolution, and fluorescence

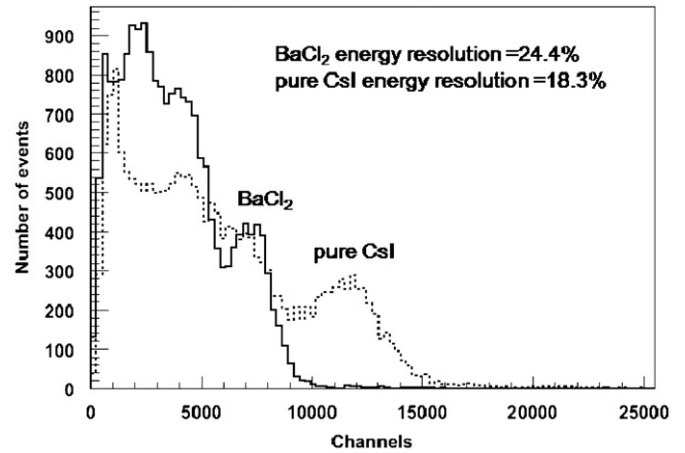

Fig. 3. Relative light yield and energy resolutions of the BaCl₂ and pure CsI for ¹³⁷Cs (662 keV) γ-ray excitation.

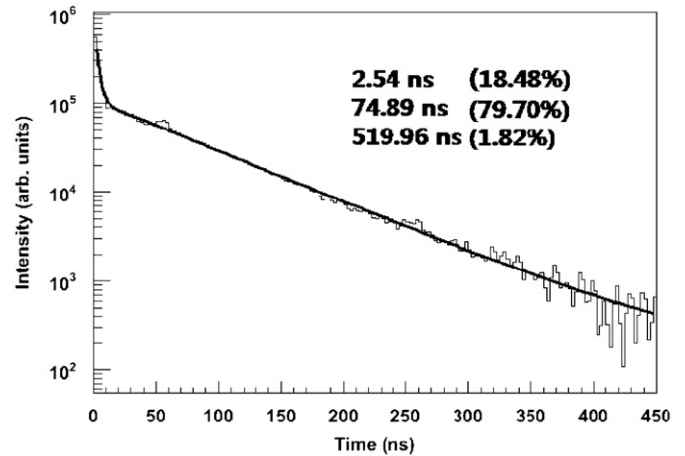

Fig. 4. Fluorescence decay time spectrum obtained from the BaCl₂ crystal at room temperature. Solid curve is the best fit to the data.

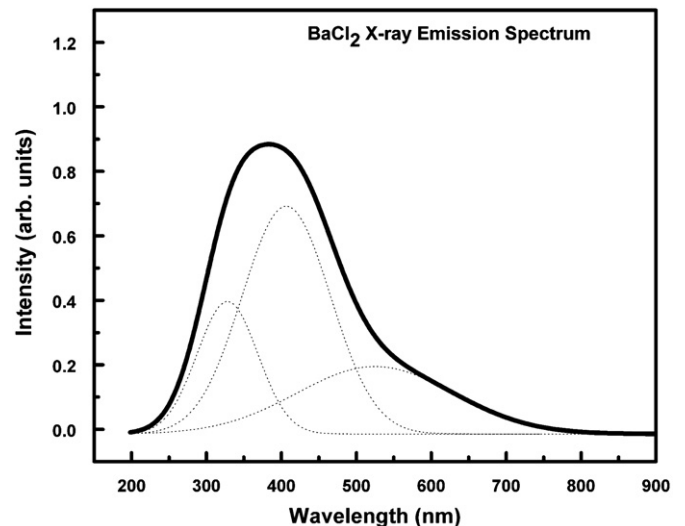

Fig. 5. Emission spectrum of the BaCl₂ crystal excited by X-ray. The peak wavelength of the BaCl₂ crystal was about 390 nm. There are three main emission peaks of 330, 410, and 530 nm.

decay time. The scintillation light of the cooled BaCl_2 crystal entered into the PMT through the quartz bar. The light transmission efficiency of the quartz bar was measured to be 35%. The readout and DAQ system for the scintillation property studies at low temperature is the same as the room temperature setup. Figs. 1 and 2 show the experimental system.

3. Scintillation properties at room temperature

3.1. Energy resolution and relative light yield

We measured the energy resolution of the BaCl_2 crystal and compared it with that of the pure CsI crystal. Fig. 3 shows light yields and energy resolutions of the BaCl_2 and CsI crystals with the ^{137}Cs (662 keV) γ -ray source. As a result of comparing the

photo-peak position of the BaCl_2 with that of the CsI crystal the light yield of the BaCl_2 crystal is 60% as small as that of the CsI crystal. The energy resolutions of the BaCl_2 and CsI were measured to be 24.4% and 18.3% (FWHM), respectively.

3.2. Fluorescence decay time

The fluorescence decay time spectrum of the BaCl_2 crystal excited by ^{137}Cs (662 keV) γ -rays was recorded at room temperature using a single photon counting technique [13,14]. The optically coupled BaCl_2 crystal with the PMT was irradiated with 662 keV photons from a radioactive source and the pulse height was recorded at room temperature. Fig. 4 shows the fluorescence decay time spectrum recorded for the BaCl_2 crystal along with three exponential fits to the data. The decay time of a very short

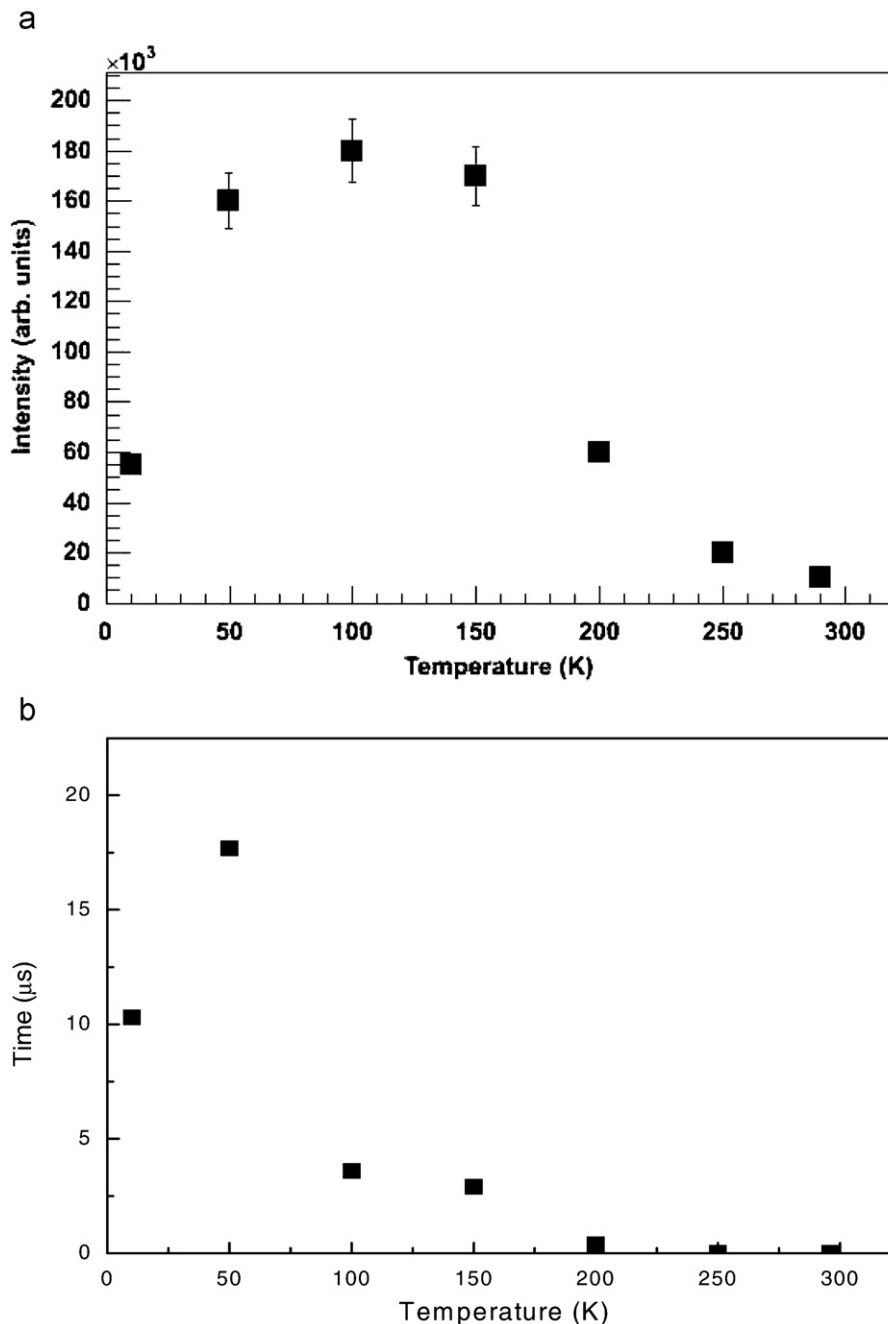

Fig. 6. Temperature dependence of (a) relative light yield and (b) mean decay time for PbWO_4 crystal. The error bars represent statistical error.

decay component was observed to be 2.54 ns (18.48%) and long decay components were measured to be 74.89 ns (79.70%) and 519.96 ns (1.82%). As shown in Fig. 4, we observed a bump around the 50–60 ns region, which can be caused by the signal reflection. Considering the fluorescence decay time of the undoped crystal scintillator strongly depends on the purity level of the sample, growing method, and characterization technique; this result is not inconsistent with the previous results [7–9].

3.3. Emission spectrum excited by X-ray

Fig. 5 shows X-ray induced emission spectrum of the BaCl₂ crystal recorded at room temperature. The emission spectrum of the BaCl₂ consisted of a broad band spanning from 250 to 700 nm wavelengths. Under the X-ray excitation, the BaCl₂ crystal showed three overlapping emission bands with a peak wavelength of 330, 410, and 530 nm. The maximum emission peak wavelength is approximately 390 nm, which matches well with the results from the bi-alkali photocathode PMT. This emission spectrum is similar with previous reports from an undoped BaCl₂ crystal [8].

4. Scintillation properties at low temperature

4.1. Performance of our low temperature system

We performed a test with a PbWO₄ crystal at low temperature for testing the low temperature system [15–17]. Fig. 6 shows the light yield and decay time of the PbWO₄ crystal. The light yields of the PbWO₄ got higher as the temperature decreased down to 100 K from room temperature. This is an expected result in Ref. [15]. The mean decay times of the PbWO₄ were recorded at low temperature under ¹³⁷Cs (662 keV) γ -rays excitation using a single photon counting technique. The mean decay time is the pulse height weighted time average, defined as

$$\langle t \rangle = \frac{\sum t_i q_i}{\sum q_i}$$

where q_i is the amplitude of the pulse at the channel time t_i up to 74 μ s. It is practically the same as the decay time of the crystal. The mean decay time of the PbWO₄ got slower as temperature decreased down to 50 K. It shows a similar decay time shape in Ref. [16]. This study shows the validity of using the refrigerator system for the characterization of scintillation crystals at low temperature.

4.2. Light yield and mean decay time

The light yield of the BaCl₂ crystal was measured with the bi-alkali PMT from emission by a 662 keV γ -ray of the ¹³⁷Cs (662 keV) γ -ray source from 10 K to room temperature. The light yield of the BaCl₂ for different temperatures is shown in Fig. 7. It is increased by changing temperature from 300 to 200 K. The light yield of the BaCl₂ at 200 K is about four times higher than that at room temperature.

Fig. 8 shows the mean decay time of the BaCl₂ crystal and that the decay time gets slower as the temperature decreases. The mean decay time of the BaCl₂ crystal at 200 K is about 12 μ s. It is twenty times slower than that of the BaCl₂ at room temperature.

Our observation of temperature dependence in light yield and decay time of the BaCl₂ crystal can be explained by the thermal quenching effect related with electron–phonon interaction and radiation-less processes. For photoluminescence, the temperature dependence of quantum efficiency is determined by the thermal change of probability in non-radiative transition. At low

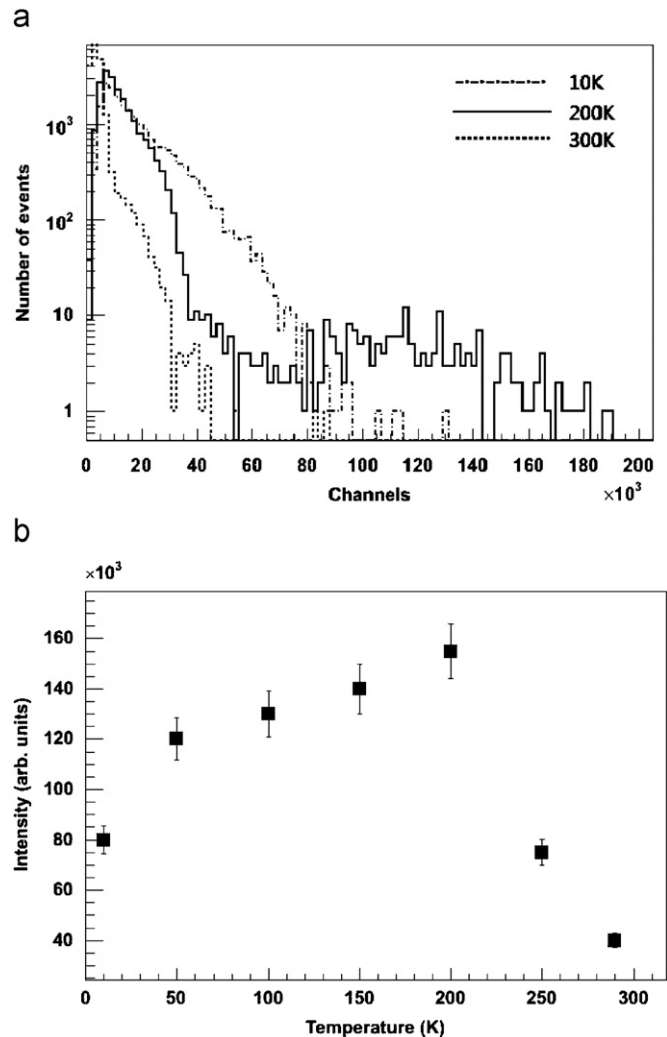

Fig. 7. (a) Pulse height spectra of the BaCl₂ crystal for different temperatures. (b) Temperature dependence on light yield for the BaCl₂ crystal.

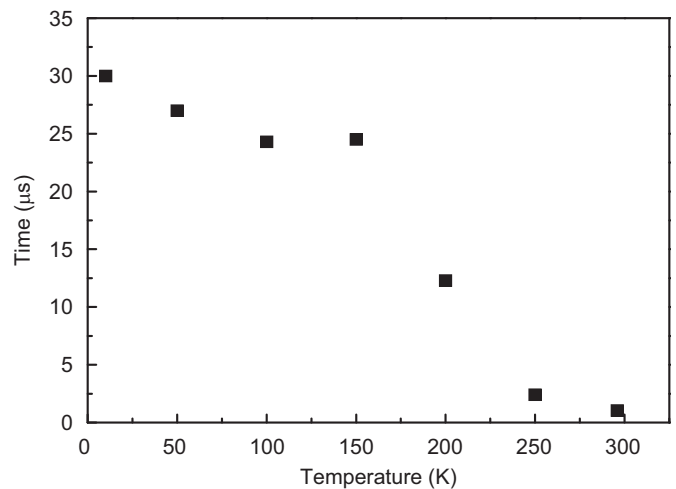

Fig. 8. Temperature dependence on the mean decay time for BaCl₂ crystal.

temperature, the radiative decay dominates and quantum efficiency is a slowly varying function with the temperature. At increasing temperature, the non-radiative decay becomes increasingly important and the luminescence is thermally quenched

within a rather small temperature range [1–3]. Pure halide crystals such as pure CsI and BaF₂ have a low light yield and fast decay time. When the temperature decreases, light yield of the halide crystal is higher than that at room temperature. The decay time of them is also slower than that at room temperature. All of these phenomena result from a quenching mechanism [18–19].

5. Conclusion

In this study, we measured the scintillation properties of the BaCl₂ crystal at room temperature. We also measured the light yield and decay time of the BaCl₂ scintillation crystal as a consideration with changing temperatures from 10 K to room temperature.

At room temperature, the energy resolution was measured to be 24.4% using a ¹³⁷Cs (662 keV) γ -ray radioactive source. We compared the photo-peak position of the BaCl₂ with that of a pure CsI crystal. The relative light yield of the BaCl₂ crystal is 60% of that of the pure CsI crystal. The decay time of the BaCl₂ was measured to be 2.54 ns (18.48%), 74.89 ns (79.70%), and 519.96 ns (1.82%). The peak wavelength of the BaCl₂ crystal was approximately 390 nm, which matches well with the bi-alkali photo-cathode PMT measurements.

At a low temperature, we measured the light yield and decay time of PbWO₄ to verify performance of our low temperature system. The measurement results are consistent with previous measurements. We then measured the scintillation properties of the BaCl₂, such as light yield and mean decay time, with change in temperature. The light yield of the BaCl₂ at 200 K was four times higher than that at room temperature and the decay time of the BaCl₂ crystal got slower as the temperature decreased. Temperature dependence with light yield and decay time of the BaCl₂ crystal can be explained by a thermal quenching mechanism.

This study showed that the BaCl₂ scintillation crystal might be a promising candidate for application into high energy physics.

Acknowledgments

This research work was supported by the World Class University (WCU) project through the National Research Foundation (NRF) of Korea funded by the Ministry of Education, Science & Technology (Grant no. R32-20001).

References

- [1] Piotr A. Rodnyi, *Physical Processes in Inorganic Scintillators*, 1st ed., CRC-Press, 1997.
- [2] Paul Lecoq, et al., *Inorganic Scintillators for Detector System*, 1st ed., Springer, 2006.
- [3] G. Blasse, et al., *Luminescent Materials*, Springer-Verlag, Telos, 1994.
- [4] Andres Aguado, et al., *J. Phys. Soc. Jpn.* 68 (1999) 2829.
- [5] J. Moon, H. Kang, H.J. Kim, W. Kim, H. Park, S. Kim, D. Kim, S.-H. Doh, *J. Korean Phys. Soc.* 49 (2006) 637.
- [6] V. Haribabu, V. Subbarao, *Prog. Cryst. Growth Charact.* 8 (1984) 189.
- [7] S.E. Derenzo et al., X-ray fluorescence measurements of 412 inorganic compounds, in: *Proceedings of the IEEE Nuclear Science Symposium Conference Record*, 1, pp. 143–147, 1991.
- [8] J. Selling, et al., *J. Appl. Phys.* 101 (2007) 034901.
- [9] Masanori Koshimizu, et al., *J. Appl. Phys.* 105 (2009) 114912.
- [10] Jungin Kim, et al., *IEEE Trans. Nucl. Sci.* 55 (2008) 1464.
- [11] <<http://www.noticekorea.com>>.
- [12] R. Brun, A. Gheata, M. Gheata, *Nucl. Instr. and Meth. A Phys. Res.* 502 (2003) 676.
- [13] Gul Rooh, Heedong Kang, H.J. Kim, H. Park, Sih-Hong Doh, *IEEE Trans. Nucl. Sci.* NS-55 (3) (2008) 1445.
- [14] Gul Rooh, et al., *J. Cryst. Growth* 311 (2008) 128.
- [15] Bo Liu, et al., *Chem. Phys. Lett.* 362 (2002) 296–300.
- [16] Zhengfu Han, et al., *J. Electron Spectrosc. Relat. Phenom.* 583 (1999).
- [17] M. Nikl, et al., *Chem. Phys. Lett.* 291 (1998) 300.
- [18] C. Amsler, et al., *Nucl. Instr. and Meth. A Phys. Res.* 408 (2002) 494.
- [19] V. Nanal, et al., *Nucl. Instr. and Meth. A Phys. Res.* 389 (1997) 430.