

## Development of Top/Bottom Counting Detectors for the CREAM Experiment on the ISS

H. J. HYUN<sup>1</sup>, T. ANDERSON<sup>2</sup>, D. ANGELASZEK<sup>3</sup>, J. B. BAE<sup>1</sup>, S. J. BAEK<sup>4</sup>, M. COPLEY<sup>3</sup>, S. COUTU<sup>2</sup>, M. GUPTA<sup>3</sup>, J. H. HAN<sup>3</sup>, H. G. HUH<sup>3</sup>, Y. S. HWANG<sup>1</sup>, I. S. JEONG<sup>4</sup>, D. H. KAH<sup>1</sup>, K. H. KANG<sup>1</sup>, H. J. KIM<sup>1</sup>, K. C. KIM<sup>3</sup>, K. KWASHNAK<sup>3</sup>, J. LEE<sup>4</sup>, M. H. LEE<sup>3</sup>, J. T. LINK<sup>5,6</sup>, L. LUTZ<sup>3</sup>, A. MALININ<sup>3</sup>, J. W. MITCHELL<sup>5</sup>, S. NUTTER<sup>7</sup>, O. OFOHA<sup>3</sup>, H. PARK<sup>1</sup>, I. H. PARK<sup>4</sup>, J. M. PARK<sup>1</sup>, P. PATTERSON<sup>3</sup>, E. S. SEO<sup>3</sup>, J. WU<sup>3</sup>, Y. S. YOON<sup>3</sup>

<sup>1</sup> Kyungpook National University, Daegu 702-701, South Korea

<sup>2</sup> Pennsylvania State University, University Park, PA 16802, USA

<sup>3</sup> University of Maryland, College Park, MD 20740, USA

<sup>4</sup> Sungkyunkwan University, Suwon 440-746, South Korea

<sup>5</sup> NASA GSFC, Greenbelt, MD 20771, USA

<sup>6</sup> CRESST(USRA), Columbia, MD 21044, USA

<sup>7</sup> Northern Kentucky University, Highland Heights, KY 41099, USA

hongjooknu@gmail.com

**Abstract:** The Cosmic Ray Energetics And Mass (CREAM) experiment is designed to measure the energy spectra from protons to iron, and thus study composition changes to understand the source and acceleration mechanisms of the high-energy cosmic rays. The instrument is planned for a launch in 2014 to the International Space Station (ISS). Two new detectors being developed for CREAM are the Top/Bottom Counting Detectors (TCD and BCD). They consist of  $500 \times 500 \times 5 \text{ mm}^3$  and  $600 \times 600 \times 10 \text{ mm}^3$  plastic scintillators, respectively, and light produced in each detector is read out with a 20 by 20 silicon photo-diode (PD) array. The TCD is located between the carbon target and the calorimeter, and the BCD is located below the calorimeter. The T/BCD configuration provides the capability for electron separation from protons, a redundant energy trigger for the calorimeter, and a cosmic-ray trigger for test and calibration on the ground. Scintillation light is produced when particles pass through the scintillators, and a PD pulse is amplified by VLSI charge amp/hold circuits. The VA-TA analog ASIC chip is used for the front-end readout electronics. The VA ASIC chip contains 32 channels each with a charge sensitive preamplifier-shaper circuit with high dynamic range, sample and hold, multiplexed analog readout, and calibration functions. The TA ASIC chip contains 32 channels of low power fast triggers. The trigger from each channel is Ored to a common trigger output. Energy information in two dimensions from the segmented PDs above and below the calorimeter provides a means to distinguish between electrons and protons. The design, construction and performance of T/BCD are presented.

**Keywords:** CREAM, Photo-diode, plastic scintillator, e/p separation

### 1 Introduction

The Cosmic Ray Energetics And Mass on the International Space Station experiment (ISS-CREAM) [1] that is planned for a launch to the ISS in 2014 aims to measure the energy spectral features from  $10^{12} \text{ eV}$  to  $>10^{15} \text{ eV}$  and composition that might be related to the supernova acceleration limit. The ISS-CREAM instrument as shown in Fig. 1 consists of a Silicon Charge Detector (SCD) to identify incident cosmic rays, a sampling tungsten/scintillator calorimeter for energy measurement of all nuclei, a segmented Top/Bottom Counting Detector for e/p separation, and a Boronated Scintillator Detector (BSD) for additional e/p separation and detecting neutron signals. In this paper, the design, construction and performance of T/BCD are described.

### 2 Design of Top and Bottom Counting Detectors

The T/BCD are designed to measure scintillation light produced when particles pass through plastic scintillator (EJ-200) that is produced by Eljen Technologies. The silicon

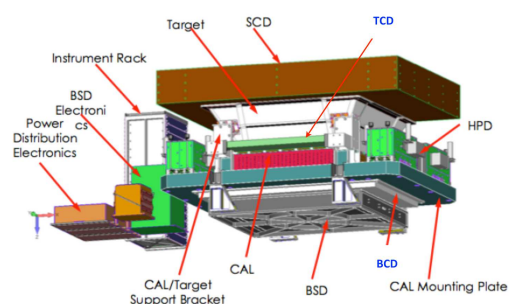

Fig. 1: ISS-CREAM instrument.

photo-diode has been chosen to convert scintillation light to electric current, and electron-hole pairs are also produced by penetrating cosmic rays. The charge signals are amplified by VLSI charge amp/hold circuits. As shown in Fig. 1, the TCD is located between the carbon target and the calorimeter, and the BCD is located below the calorimeter. This configuration enables electron/proton (e/p) separation by the difference between electromagnetic and hadron-

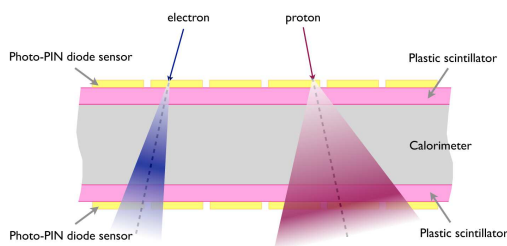

Fig. 2: Operational principle of the T/BCD.

ic showers (Fig. 2). The TCD and BCD each has a total of 400 PDs and the PDs cover  $500 \times 500 \text{ mm}^2$  and  $600 \times 600 \text{ mm}^2$ , respectively. Energy information in two dimensions from the segmented PDs above and below the calorimeter provides a means to distinguish electrons from protons. Figure 3 shows exploded views of both detectors. The dimensions of the T/BCD enclosures are  $900 \times 535 \times 30 \text{ mm}^3$  and  $950 \times 651 \times 33 \text{ mm}^3$ , respectively. In the case of the TCD, the electronic components are on the opposite side of the PD array and the plastic scintillators. The connections between the T/BCD electronics and common ISS-CREAM electronics are shown schematically in Fig. 4.

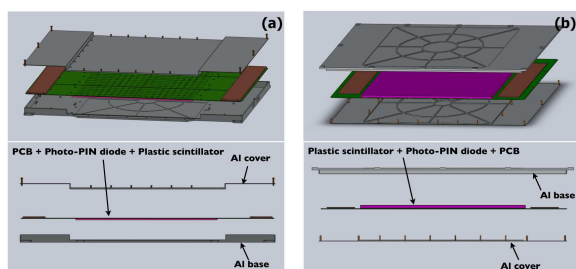

Fig. 3: Exploded view of the (a) TCD, and (b) BCD.

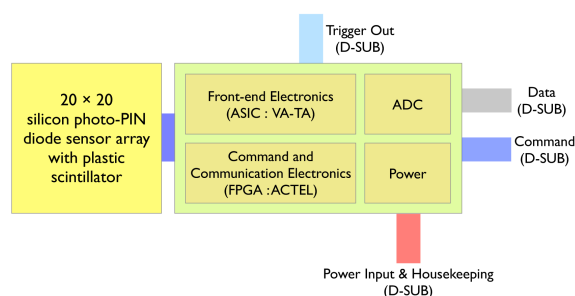

Fig. 4: Schematic diagram of the T/BCD.

### 3 Silicon Photo-Diode

Silicon photo-diodes (PD) each with an active area of  $2.0 \text{ cm} \times 2.0 \text{ cm}$  are custom developed for the T/BCD. The PD is coupled with the plastic scintillator and is designed to be a back-illuminated photo-sensor to increase the light detection area [2]. The PD detects incoming light that is converted from the scintillator. The PD is operated by full depletion bias voltage. Therefore the PD can detect not only scintillation light, but also incoming charged particle. The PD is fabricated on 6-inch, high resistivity,  $\langle 100 \rangle$ ,

650  $\mu\text{m}$  thick, and n-type silicon wafers. Figure 5 shows both sides of the fabricated silicon wafer. There are 18 PDs for the T/BCD and test patterns such as  $1.0 \text{ cm} \times 1.0 \text{ cm}$  PDs and PD pixel arrays.

We measure leakage current and bulk capacitance of the fabricated PDs with a Keithley 6517 picoammeter and an HP 4277A LCZ meter as a function of reverse bias voltages, respectively. Measurement results are shown in Fig. 6. From bulk capacitance measurement, the full depletion voltage is found to be below  $-200 \text{ V}$  and the optimal operating voltage is determined to be  $-250 \text{ V}$ . The leakage current is below  $20 \text{ nA/cm}^2$  at the operating voltage. A stability test for leakage current is being performed at the operating voltage.

The photo response over the wavelength range from 350 nm to 1100 nm is measured at the Korea Research Institute of Standards and Science (KRISS) [3] and the quantum efficiency is obtained to be  $60 \sim 75 \%$  for the wavelength range from 400 to 450 nm, which is a wavelength range of the plastic scintillator. The Signal-to-Noise Ratio (SNR) of the PD is also measured using a  $^{90}\text{Sr}$  radioactive source. The measured SNR is better than 70 with commercial electronics. The radiation hardness of the PD is also tested by using a 45 MeV proton beam at the Korea Institute of Radiological and Medical Sciences (KIRAMS) [4]. The PD sensor is exposed to  $1.18 \times 10^{11}$  protons/ $\text{cm}^2$ , which corresponds to  $> 5000 \text{ rad}$ . The leakage current is increased up to about  $50 \text{ nA/cm}^2$  but the quality of the PD sensor does not change in our criteria for the best sensor ( $< 100 \text{ nA/cm}^2$ )

### 4 Readout Electronics

The readout electronics consists of two mother boards and 4 daughter boards for each TCD and BCD as shown in Fig. 7. On the mother board, there is an FPGA chip in addition to the VA-TA (VA32HDR-TA32CG3) : Viking chips from the IDEAS company. The VA has 32 channels and each channel consists of a charge sensitive preamplifier, a slow shaper, and a sample-and-hold circuit. The output of all channels is connected to the multiplexer and the analog signals are serially clocked out. Noise and dynamic range of the VA are  $\sim 3100 \text{ e}^-_{\text{rms}}$  and  $\sim 13 \text{ pC}$ , respectively. The TA is 32 channel low power fast triggering ASIC chip to be used with a matching VA circuit in the front. Each channel includes a fast CR-RC 75 ns shaper followed by a level-sensitive discriminator, whose threshold is externally adjustable. Whenever a signal in any of the channels is rising above the threshold, the wire-or'ed output will cause a chip-global trigger. Therefore VA-TA chips receive the charge signal from the PD, perform signal amplification

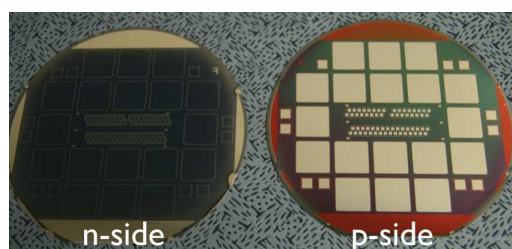
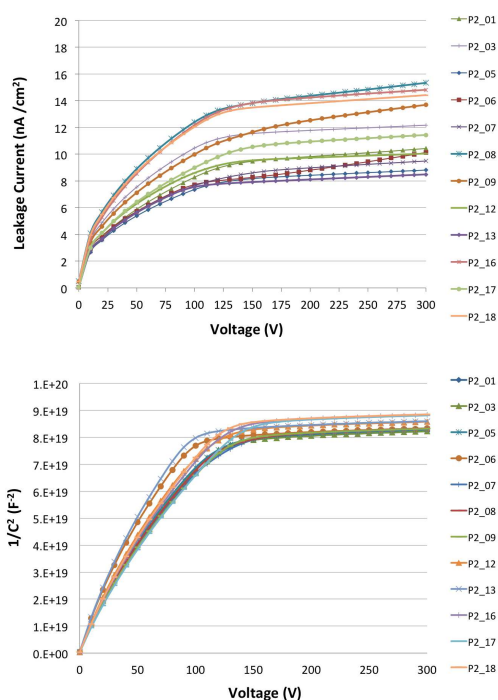

Fig. 5: Photograph of the photo-diodes on 6-inch and 650  $\mu\text{m}$  thickness silicon wafer.



**Fig. 6:** Leakage currents (top) and bulk capacitance (bottom) of the photo-diodes as a function of the reverse bias voltages.

followed by shaping, and provide a trigger signal. 16 bit Analog to Digital Converter (ADC) digitizes the sample-and-hold signals of the VA-TA. Commands from the Sparsification and Command boards pass through the FPGA and control the VA-TA, ADC, and Digital to Analog Converter (DAC). The TA sends trigger signals to the trigger module. Figure 8 shows signal flows of the T/BCD readout electronics.

The prototype readout electronics with the VA-TA and the PD that is coupled with the plastic scintillator is tested with radioactive sources for example  $^{241}\text{Am}$  and  $^{90}\text{Sr}$ . Using the  $^{241}\text{Am}$  source, the peak hold delay time is studied and the DAC value for the hold delay is found to be 115 DAC. Figure 9 shows a pulse height distribution of one channel, which is taken by using the  $^{241}\text{Am}$  source. The threshold for trigger and hold delay time are set to be 300 DAC and 115 DAC, respectively. The left-hand peak is due to the pedestal and the right-hand peak is due to the signal. A trigger efficiency study using the  $^{90}\text{Sr}$  source and a calibration test with input charge from 0 DAC to 6000 DAC are in progress. To provide the minimum ionizing particle (MIP) trigger to the entire ISS-CREAM system, the SNR of the T/BCD should be greater than 5. For achieving this goal, we need to study how to reduce the noise of the system.

## 5 Conclusions

We have developed the T/BCD for CREAM, which is planned to launch to the International Space Station in 2014. The TCD is located between the carbon target and the calorimeter, and the BCD is located below the calorimeter. The T/BCD are designed to optimize e/p separation by using the difference between electromagnetic and hadron-

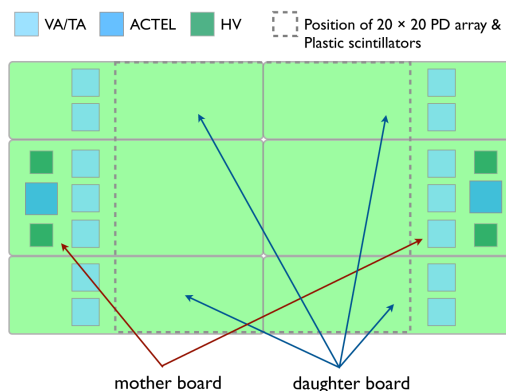

**Fig. 7:** Design of T/BCD electronics. There are two mother boards and four daughter boards for each of the TCD and BCD.

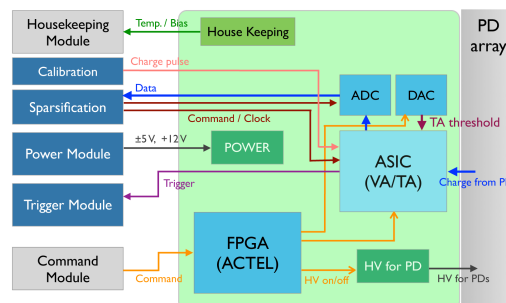
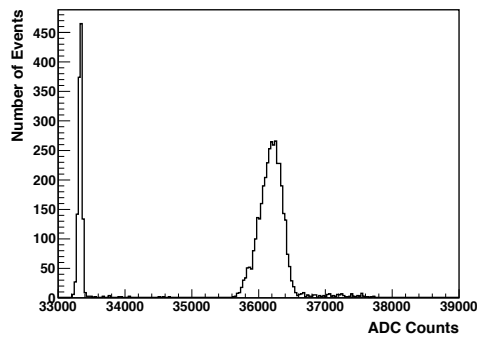

**Fig. 8:** Signal flows in the T/BCD readout electronics and ISS-CREAM common electronics.

ic showers. Both detectors consist of EJ-200 plastic scintillator and an array of 400 photo-diodes. The PDs are fabricated for the T/BCD and assembled with the plastic scintillator, which cover  $500\text{ mm} \times 500\text{ mm}$  and  $600\text{ mm} \times 600\text{ mm}$ , respectively.

The custom developed PD, each with actual size of  $2.3\text{ cm} \times 2.3\text{ cm}$  shows good electrical characteristics. The leakage current is below  $20\text{ nA/cm}^2$  at operating voltage. The Signal-to-Noise Ratio is measured to be better than 70 with commercial electronics and radiation hardness is also tested using a proton beam. The VA-TA Viking chip from IDEAS is used at the core of the front-end electronics. The VA has large dynamic range, low noise, and low power consumption ( $\sim 3\text{ mW/channel}$ ). The TA provides the self-triggering functionality. The charge signals from the PD are processed by the VA and then digitized by a 16 bit ADC. The prototype readout electronics with the VA-TA and the PD that is coupled with the plastic scintillator has been tested by using radioactive sources such as  $^{241}\text{Am}$  and  $^{90}\text{Sr}$ . The peak hold delay time is found. Trigger efficiency and calibration tests are in progress.

**Acknowledgment:** The authors thank NASA Goddard Space Flight Center (GSFC) Wallops Flight Facility for project management and engineering support, and NASA Johnson Space Center ISS Program Office for the launch support and the ISS accommodation. This work was supported in the U.S. by NASA grants NNX11AC52G, NNX08AC15G, NNX08AC16G and their predecessor grants, as well as by directed RTOP funds to the NASA GSFC. It is supported in Korea by the Creative Research Initiatives of MEST/NRF and by a National Research Foundation



**Fig. 9:** Pulse height distribution of one channel on the prototype readout electronics. Left peak is a pedestal and right peak is a signal by alpha of a  $^{241}\text{Am}$  source.

(NRF) of Korea grant funded (NRF-2011-0016260, NRF-2011-0021196).

## References

- [1] E. S. Seo, *Astropart. Phys.*, 39/40 (2012) 76-87  
<http://dx.doi.org/10.1016/j.astropartphys.2012.04.002>.
- [2] D.H. Kah et al., *Nucl. Instr. and Meth. A* 628 (2011) 256.
- [3] Korea Research Institute of Standards and Science, Daejeon, Korea, <http://www.kriss.re.kr>.
- [4] Korea Institute of Radiological and Medical Sciences, Seoul, Korea, <http://www.kirams.re.kr>.